

# Positive Doubling Charge Pump with Shutdown in SOT Package

## FEATURES

- Space Saving 6-Pin SOT-23A Package
- >99% Typical Voltage Conversion Efficiency
- Voltage Doubling
- Operates from +2.5V to +4.0V
- Low Output Resistance (17Ω Typical)
- Only Two External Capacitors Required
- Consumes 180μA (Typical) in Active Mode
- Power-Saving Shutdown Mode (1μA Maximum)
- Fully Compliant with 1.8V Logic Systems

## APPLICATIONS

- Cellular Phones
- Pagers
- PDAs, Portable Dataloggers
- Battery-Powered Devices
- Handheld Instruments

## GENERAL DESCRIPTION

The TC1240 is a doubling CMOS charge-pump voltage converter in a small 6-Pin SOT-23A package. TC1240 doubles an input voltage which can range from +2.5V to +4.0V. Conversion efficiency is typically >99%. Internal oscillator frequency is 160kHz for the TC1240. The TC1240 has an active high shutdown which limits the current consumption of the device to less than 1μA.

External component requirement is only two capacitors for standard voltage doubler applications. All other circuitry, including control, oscillator, power MOSFETs are integrated on-chip. Typical supply current is 180μA and the device is available in a 6-Pin SOT-23A surface mount package.

## ORDERING INFORMATION

Part Number	Package	Temp. Range
TC1240ECH	6-Pin SOT-23A	-40°C to +85°C

## TYPICAL OPERATING CIRCUIT

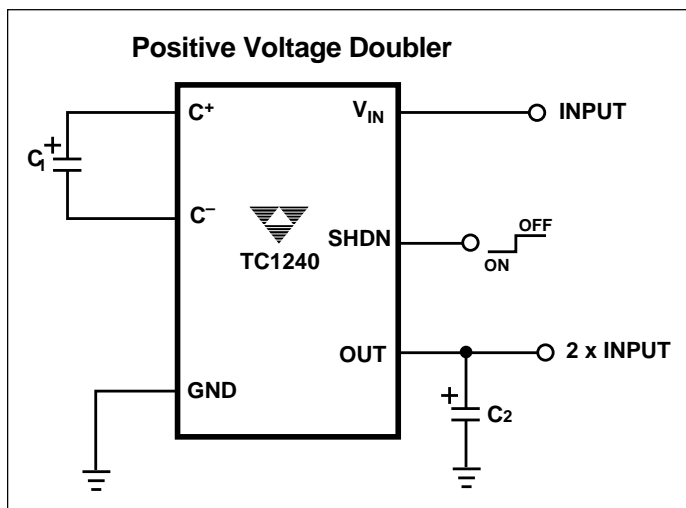

## PIN CONFIGURATION

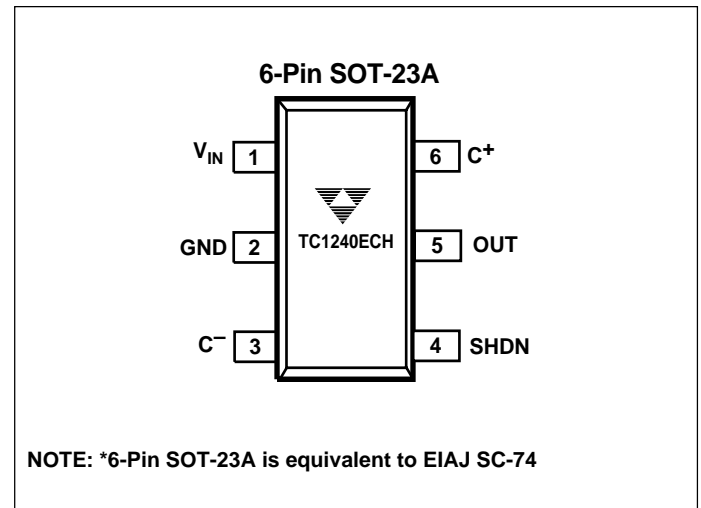

# Positive Doubling Charge Pump with Shutdown in SOT Package

## TC1240

### ABSOLUTE MAXIMUM RATINGS\*

Input Voltage ( $V_{IN}$ to GND) .....	+4.5V, -0.3V
Output Voltage (OUT to GND) .....	+9.0V, $V_{IN} - 0.3V$
Current at OUT Pin .....	50 mA
Short-Circuit Duration -OUT to GND .....	Indefinite
Operating Temperature Range .....	-40 °C to +85°C
Power Dissipation ( $T_A \leq 70^\circ\text{C}$ )	
6-Pin SOT-23A .....	240 mW
Storage Temperature (Unbiased) .....	-65 °C to +150°C
Lead Temperature (Soldering, 10 sec) .....	+300°C

\*Static-sensitive device. Unused devices must be stored in conductive material. Protect devices from static discharge and static fields. Stresses above those listed under Absolute Maximum Ratings may cause permanent damage to the device. These are stress ratings only and functional operation of the device at these or any other conditions above those indicated in the operational sections of the specifications is not implied. Exposure to Absolute Maximum Rating Conditions for extended periods may affect device reliability.

**ELECTRICAL CHARACTERISTICS:**  $T_A = -40$  to  $+85$  °C,  $V_{IN} = +2.8V$ ,  $C1 = C2 = 3.3\mu F$ , SHDN = GND, unless otherwise noted. Typical values are at  $T_A = +25^\circ\text{C}$ .

Symbol	Parameter	Test Conditions	Min	Typ	Max	Units
IDD	Supply Current	$R_{LOAD} = \infty$	—	180	300	$\mu\text{A}$
ISHDN	Shutdown Supply Current	SHDN = $V_{IN}$	—	0.1	1.0	$\mu\text{A}$
$V_{MIN}$	Minimum Supply Voltage	$R_{LOAD} = 1.0K\Omega$	2.5	—	—	V
$V_{MAX}$	Maximum Supply Voltage	$R_{LOAD} = 1.0K\Omega$	—	—	4.0	V
FOSC	Oscillator Frequency	$T_A = -40$ °C to $+85^\circ\text{C}$	—	160	—	kHz
F <sub>SW</sub>	Switching Frequency	$T_A = -40$ °C to $+85^\circ\text{C}$	40	80	125	kHz
$V_{IH}$	Shutdown Input Logic High	$V_{IN} = V_{MIN}$ to $V_{MAX}$	1.4	—	—	V
$V_{IL}$	Shutdown Input Logic Low	$V_{IN} = V_{MIN}$ to $V_{MAX}$	—	—	0.4	V
P <sub>EFF</sub>	Power Efficiency	$R_{LOAD} = 1.0K\Omega$	86	93	—	%
V <sub>EFF</sub>	Voltage Conversion Efficiency	$R_{LOAD} = \infty$	97.5	99.96	—	%
R <sub>OUT</sub>	Output Resistance (Note 1)	$R_{LOAD} = 1.0K\Omega$ $T_A = -40^\circ\text{C}$ to $+85^\circ\text{C}$	—	17	—	$\Omega$
			—	—	30	

NOTE: 1. Capacitor contribution is approximately 26% of the output impedance [ESR = 1 / pump frequency x capacitance].  
2. Switching frequency is one-half internal oscillator frequency.

### PIN DESCRIPTION

Pin No. (6-Pin SOT-23A)	Symbol	Description
1	$V_{IN}$	Power Supply Input.
2	GND	Ground.
3	C-	Commutation Capacitor Negative Terminal.
4	SHDN	Shutdown Input (Active High).
5	OUT	Doubled Output Voltage.
6	C+	Commutation Capacitor Positive Terminal.

# Positive Doubling Charge Pump with Shutdown in SOT Package

TC1240

## DETAILED DESCRIPTION

The TC1240 charge pump converter doubles the voltage applied to the  $V_{IN}$  pin. Conversion consists of a two-phase operation (Figure 1). During the first phase, switches S2 and S4 are open and S1 and S3 are closed. During this time, C1 charges to the voltage on  $V_{IN}$  and load current is supplied from C2. During the second phase, S2 and S4 are closed, and S1 and S3 are open.

During this second phase, C1 is level shifted upward by  $V_{IN}$  volts. This connects C1 to the reservoir capacitor C2, allowing energy to be delivered to the output as needed. The actual voltage is slightly lower than  $2 \times V_{IN}$  since the four switches (S1 - S4) have an on-resistance and the load drains charge from reservoir capacitor C2.

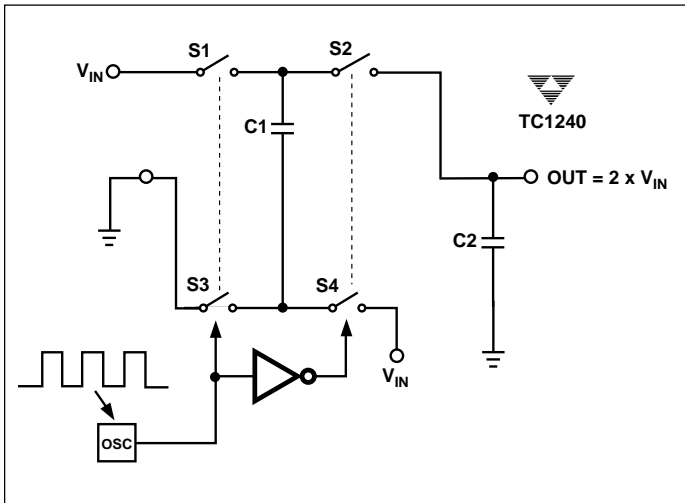

Figure 1. Ideal Switched Capacitor Charge Pump Doubler

## APPLICATIONS INFORMATION

### Output Voltage Considerations

The TC1240 performs voltage doubling but does not provide regulation. The output voltage will droop in a linear manner with respect to load current. The value of this equivalent output resistance is approximately  $17\Omega$  nominal at  $+25^\circ\text{C}$  and  $V_{IN} = +2.8\text{V}$ .  $V_{OUT}$  is approximately  $+5.6\text{V}$  at light loads, and droops according to the equation below:

$$V_{DROOP} = I_{OUT} \times R_{OUT}$$

$$V_{OUT} = 2 \times V_{IN} - V_{DROOP}$$

### Charge Pump Efficiency

The overall power efficiency of the charge pump is affected by four factors:

(1) Losses from power consumed by the internal oscillator, switch drive, etc. (which vary with input voltage, temperature and oscillator frequency).

(2)  $I^2R$  losses due to the on-resistance of the MOSFET switches on-board the charge pump.

(3) Charge pump capacitor losses due to effective series resistance (ESR).

(4) Losses that occur during charge transfer (from commutation capacitor to the output capacitor) when a voltage difference between the two capacitors exists.

Most of the conversion losses are due to factors (2) and (3) above. These losses are given by Equation 1(b).

$$(a) P_{LOSS(2,3)} = I_{OUT}^2 \times R_{OUT}$$

$$(b) \cong I_{OUT}^2 \times \left[ \frac{1}{(f_{PUMP}) C_1} + 8R_{SWITCH} + 4ESR_{C1} + ESR_{C2} \right]$$

Equation 1.

The pump frequency in Equation 1(b) is defined as one-half the oscillator frequency (i.e.  $f_{PUMP} = f_{OSC}/2$ ). The  $1/(f_{PUMP})(C_1)$  term in Equation 1(b) is the effective output resistance of an ideal switched capacitor circuit (Figures 2a, 2b). The value of  $R_{SWITCH}$  can be approximated at  $1.4\Omega$  for the TC1240.

The remaining losses in the circuit are due to factor (4) above, and are shown in Equation 2. The output voltage ripple is given by Equation 3.

$$P_{LOSS(4)} = [(0.5)(C_1) (4V_{IN}^2 - V_{OUT}^2) + (0.5)(C_2)(2V_{OUT} V_{RIPPLE} - V_{RIPPLE}^2)] \times f_{OSC}$$

Equation 2.

$$V_{RIPPLE} = \frac{I_{OUT}}{(f_{OSC})(C_2)} + 2(I_{OUT})(ESR_{C2})$$

Equation 3.

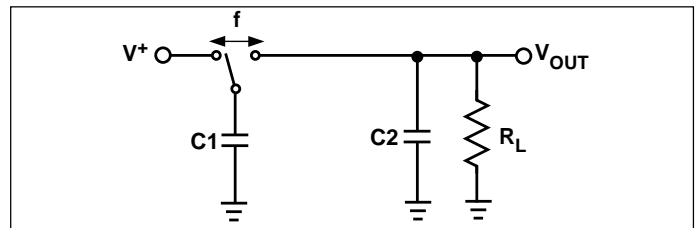

Figure 2a. Ideal Switched Capacitor Model

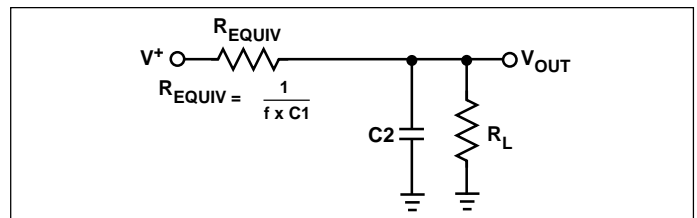

Figure 2b. Equivalent Output Resistance

# Positive Doubling Charge Pump with Shutdown in SOT Package

## TC1240

### CAPACITOR SELECTION

In order to maintain the lowest output resistance and output ripple voltage, it is recommended that low ESR capacitors be used. Additionally, larger values of C1 will lower the output resistance and larger values of C2 will reduce output ripple. (See Equation 1(b)).

Table 1 shows various values of C1 and the corresponding output resistance values @ +25°C. It assumes a 0.1Ω ESR<sub>C1</sub> and 1.2Ω R<sub>SW</sub>. Table 2 shows the output voltage ripple for various values of C2. The V<sub>RIPPLE</sub> values assume 5 mA output load current and 0.1Ω ESR<sub>C2</sub>.

**Table 1. Output Resistance vs. C1 (ESR = 0.1Ω)**

C1 (μF)	TC1240 R <sub>OUT</sub> (Ω)
0.47	47
1	28.5
2.2	19.5
3.3	17
4.7	15.5
10	13.6
47	12.5
100	12.2

**Table 2. Output Voltage Ripple vs. C2 (ESR = 0.1Ω) I<sub>OUT</sub> 5mA**

C1 (μF)	TC1240 V <sub>RIPPLE</sub> (mV)
0.47	142
1	67
2.2	30
3.3	20
4.7	14
10	6.7
47	2.5
100	1.6

### INPUT SUPPLY BYPASSING

The V<sub>IN</sub> input should be capacitively bypassed to reduce AC impedance and minimize noise effects due to the switching internal to the device. The recommended capacitor should be a large value (at least equal to C1) connected from the input to GND.

### SHUTDOWN INPUT

The TC1240 is disabled when SHDN is high, and enabled when SHDN is low. This input cannot be allowed to float.

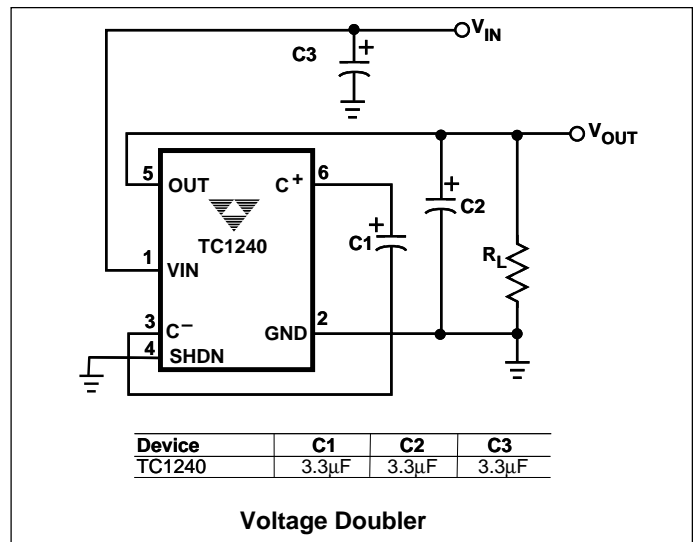

**Figure 3. Test Circuit**

### VOLTAGE DOUBLER

The most common application for charge pump devices is the doubler (Figure 3). This application uses two external capacitors - C1 and C2 (plus a power supply bypass capacitor, if necessary). The output is equal to 2 x V<sub>IN</sub> minus any voltage drops due to loading. Refer to Table 1 and Table 2 for capacitor selection.

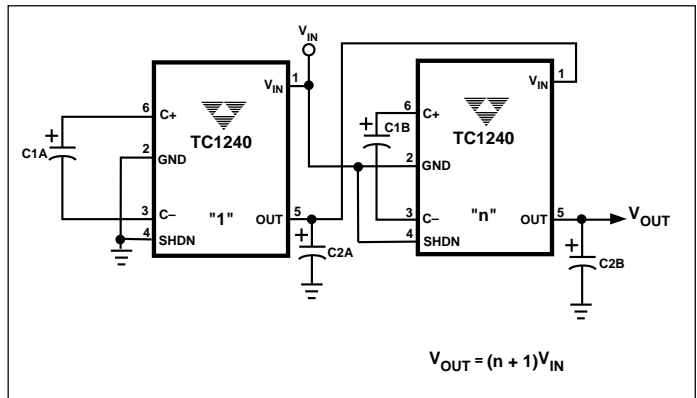

**Figure 4. Cascading Multiple Devices to Increase Output Voltage**

### CASCADING DEVICES

Two or more TC1240s can be cascaded to increase output voltage (Figure 4). If the output is lightly loaded, it will be close to ((n + 1) x V<sub>IN</sub>) but will droop at least by R<sub>OUT</sub> of the first device multiplied by the I<sub>Q</sub> of the second. It can be seen that the output resistance rises rapidly for multiple cascaded devices. For the case of the two-stage 'tripler' output resistance can be approximated as R<sub>OUT</sub> = 2 x R<sub>OUT1</sub> + R<sub>OUT2</sub>, where R<sub>OUT1</sub> is the output resistance of the first stage, and R<sub>OUT2</sub> is the output resistance of the second stage.

# Positive Doubling Charge Pump with Shutdown in SOT Package

TC1240

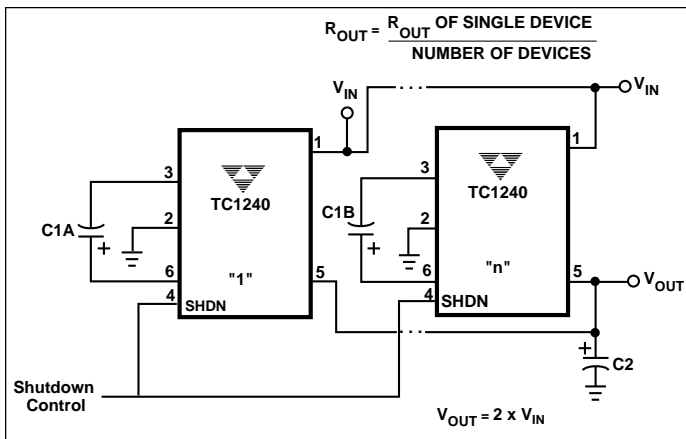

Figure 5. Paralleling Multiple Devices to Reduce Output Resistance

## PARALLELING DEVICES

To reduce the value of  $R_{OUT}$ , multiple TC1240s can be connected in parallel (Figure 5). The output resistance will be reduced by a factor of  $N$  where  $N$  is the number of TC1240s. Each device will require its own pump capacitor ( $C1x$ ), but all devices may share one reservoir capacitor ( $C2$ ).

However, to preserve ripple performance the value of  $C2$  should be scaled according to the number of paralleled TC1240s.

## LAYOUT CONSIDERATIONS

As with any switching power supply circuit good layout practice is recommended. Mount components as close together as possible to minimize stray inductance and capacitance. Also use a large ground plane to minimize noise leakage into other circuitry.

## TC1240 DEMO CARD

The TC1240 Demo Card is a 1.25" x 1.0" card containing a TC1240 and all of the necessary external components that allow the user to evaluate the device's ability to generate a 2X non-regulated output voltage. The demo card is fully assembled with the required external capacitors along with a variable load resistor that allows the user to vary the output load current of the output stage. For convenience, several test points and jumpers are available for measuring various voltages and currents on the circuit board.

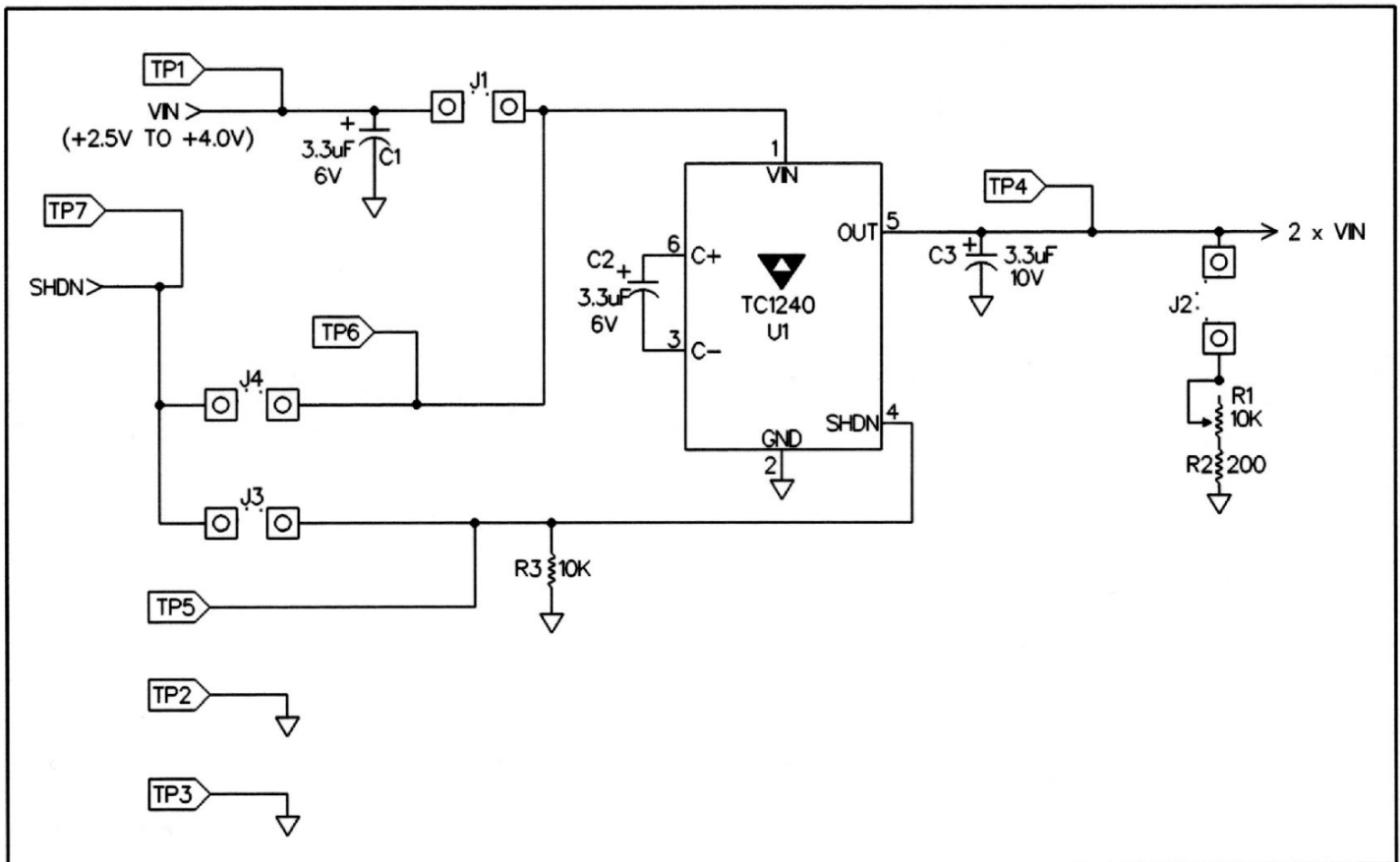

Figure 6. TC1240 Demo Card Schematic

# Positive Doubling Charge Pump with Shutdown in SOT Package

## TC1240

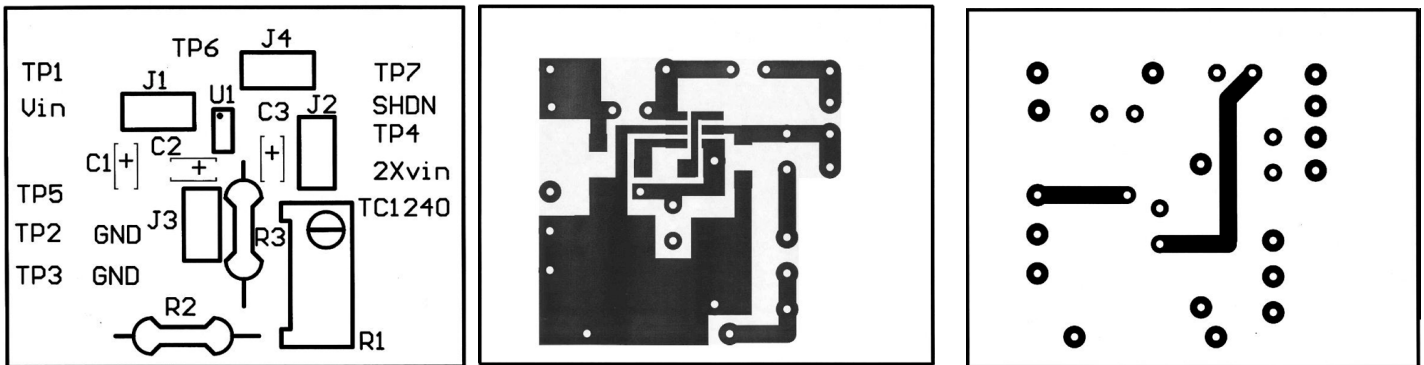

Figure 7. TC1240 Demo Card Assembly Drawing and Artwork

Figure 6 is a schematic of the TC1240 Demo Card, and Figure 7 shows the assembly drawing and artwork for the board. Table 3 lists the voltages that are monitored by the test points and Table 4 lists the currents that can be measured using the jumpers or the specific jumper function.

Table 3. TC1240 Demo Card Test Points

TEST POINT	VOLTAGE MEASUREMENT
TP1	DEMO CARD POWER SUPPLY INPUT[+2.5V to +4.0V]
TP2	GROUND
TP3	GROUND
TP4	TC1240 OUTPUT (2 x VIN)
TP5	TC1240 SHDN INPUT
TP6	TC1240 VIN SUPPLY VOLTAGE
TP7	EXTERNAL SHDN INPUT

Table 4. TC1240 Demo Card Jumpers

JUMPER	CURRENT MEASUREMENT / JUMPER FUNCTION
J1	TC1240 QUIESCENT CURRENT
J2	TC1240 LOAD CURRENT
J3	TC1240 SHDN INPUT CURRENT
J4	CONNECT EXTERNAL SHDN INPUT TO VIN (i.e. SHDN ENABLE)

# Positive Doubling Charge Pump with Shutdown in SOT Package

TC1240

## TYPICAL CHARACTERISTICS

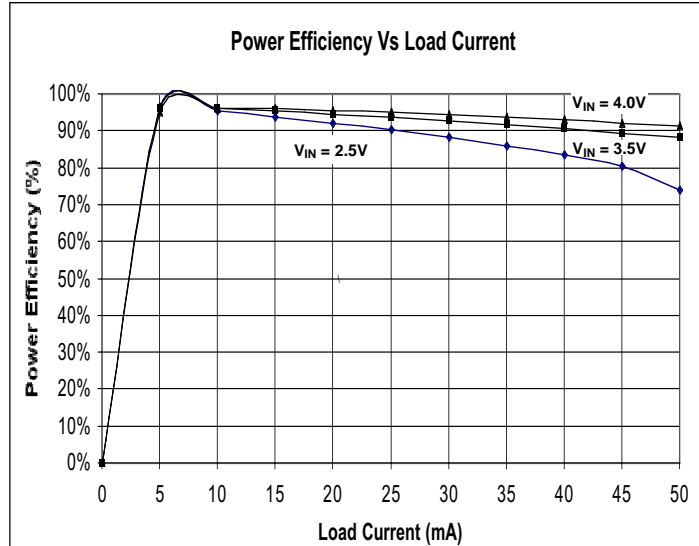
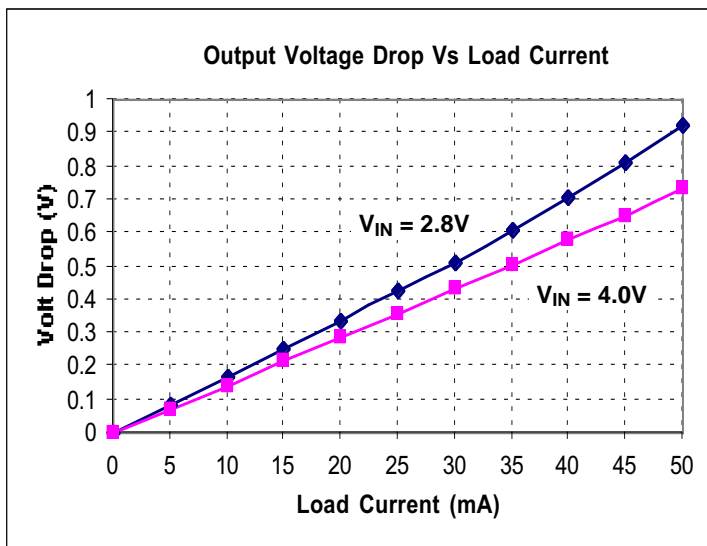
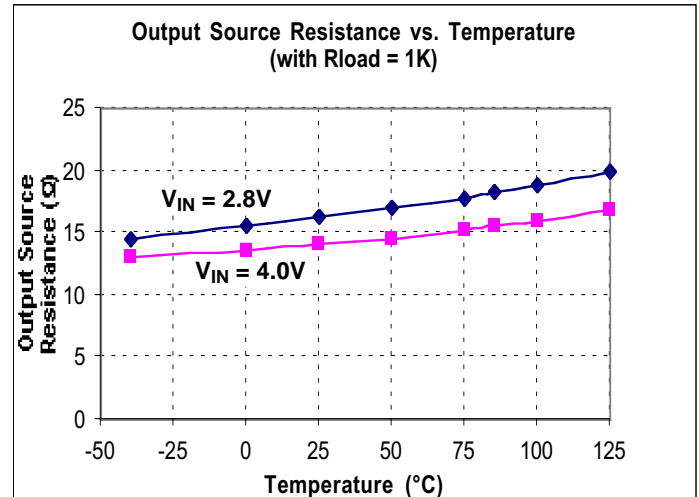
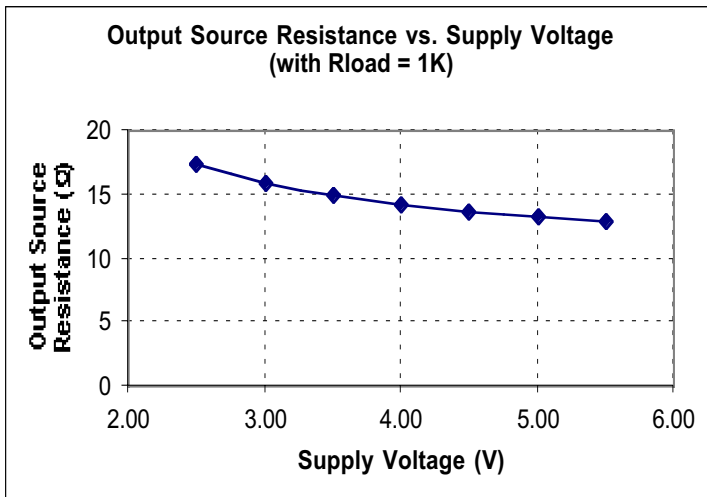
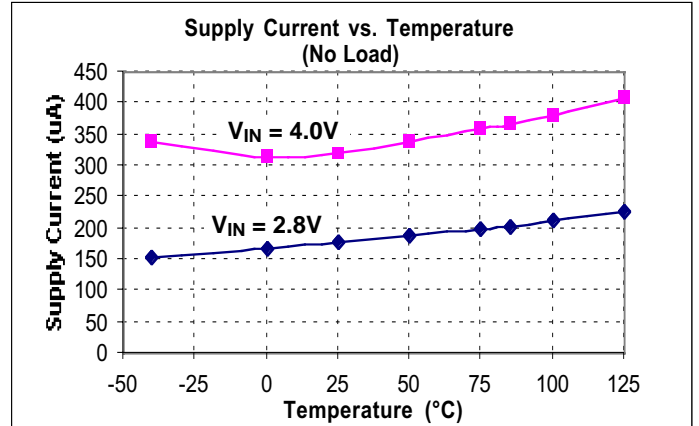
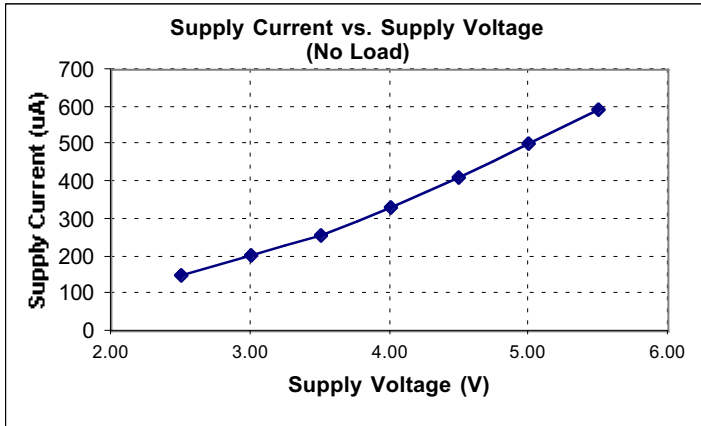

# Positive Doubling Charge Pump with Shutdown in SOT Package

## TC1240

### TYPICAL CHARACTERISTICS (Cont.)

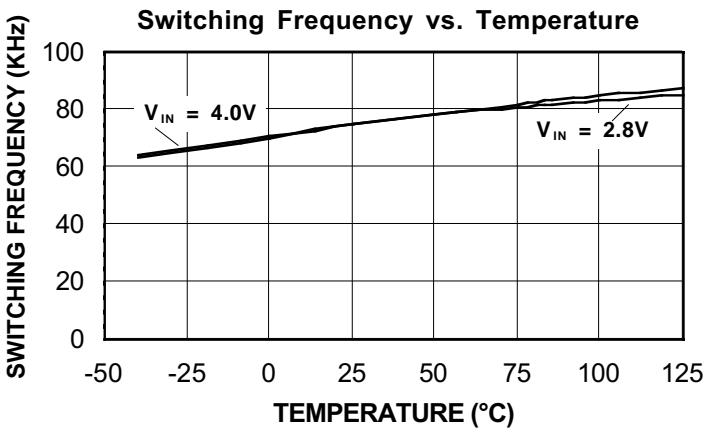

### MARKING

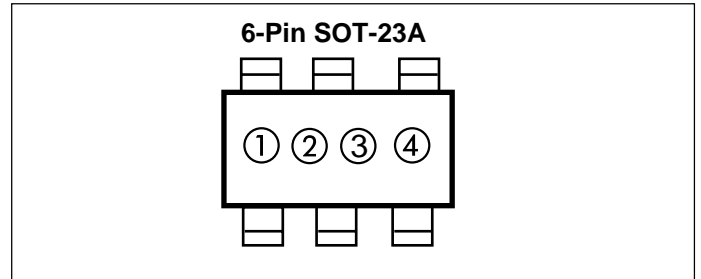

① & ② represent part number code + temperature range (two-digit code)

**TC1240**      **Code**

1240ECH      DN

Ex: 1240ECH = (D) (N) ○ ○

③ represents year and 2-month code

④ represents lot ID number

### TAPING FORM

#### Component Taping Orientation for 6-Pin SOT-23A (EIAJ SC-74) Devices

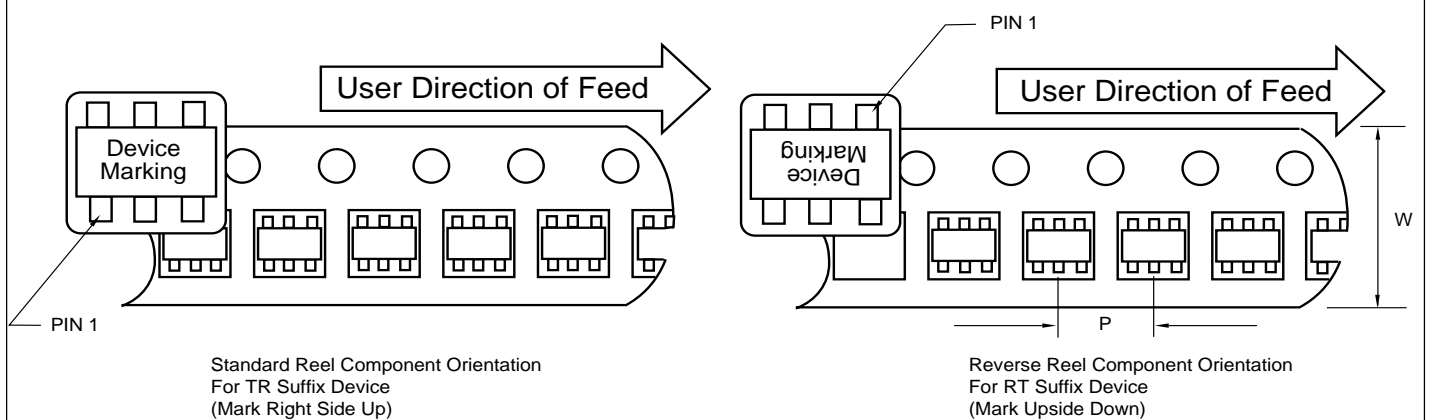

#### Carrier Tape, Number of Components Per Reel and Reel Size

Package	Carrier Width (W)	Pitch (P)	Part Per Full Reel	Reel Size
6-Pin SOT-23A	8 mm	4 mm	3000	7 in



# Positive Doubling Charge Pump with Shutdown in SOT Package

TC1240

## PACKAGE DIMENSIONS

### 6-Pin SOT-23A (EIAJ SC-74)

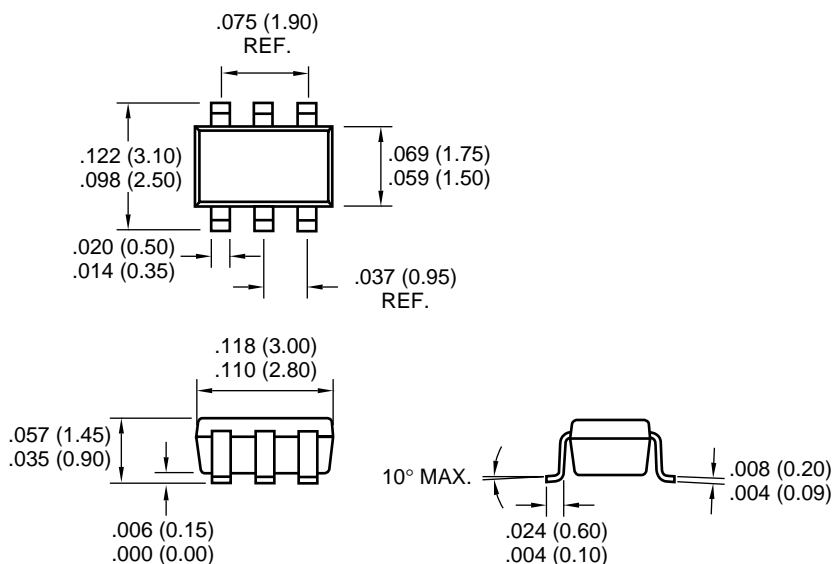

Dimensions: inches (mm)

## Sales Offices

**TelCom Semiconductor, Inc.**  
1300 Terra Bella Avenue  
P.O. Box 7267  
Mountain View, CA 94039-7267  
TEL: 650-968-9241  
FAX: 650-967-1590  
E-Mail: liter@telcom-semi.com

**TelCom Semiconductor, GmbH**  
Lochhamer Strasse 13  
D-82152 Martinsried  
Germany  
TEL: (011) 49 89 895 6500  
FAX: (011) 49 89 895 6502 2

**TelCom Semiconductor H.K. Ltd.**  
10 Sam Chuk Street, Ground Floor  
San Po Kong, Kowloon  
Hong Kong  
TEL: (011) 852-2350-7380  
FAX: (011) 852-2354-9957